





# SS65

## Roll Up Doors

SSCORNERSTONE's self storage doors and solutions are fabricated to meet the demands of the industry. Our industry leading 3rd generation roll up doors provide quick and easy installation, minimal maintenance, superior strength and exceptional durability. They are ideal for storage within carports, barns, sheds and self storage commercial unit mix.

### Components

-  **1. 26 - Gauge corrugated door curtain**  
Manufactured from galvanized grade 80 steel and coated with super durable polyester paint in more than 10 color options.
-  **2. Pre - lubricated springs**  
During production, springs are factory lubricated and enclosed in a tube to protect them from the environmental elements.
-  **3. Dead axle and barrel assembly**  
An enclosed spiral barrel houses the dead axle assembly and offers durability and smoother operation as weight is distributed throughout the barrel.
-  **4. Ratched tensioning device**  
Allows you to simultaneously fine tune springs due to the eight different positions on the tension wheel, which provides equal pull on the left and right sides to ensure balanced operation of the door.

All **DRUMS** are fitted with a grease filled, shielded radial ball bearing to contribute to a smoother operation and reduce wear and friction.

Factory installed galvanized reinforced 16 - gauge **BRACKETS** are designed to easily bolt or snap into the guides, reducing installation time.

Galvanized, guide-mounted **HEAD STOPS** are simple to install and prevent curtain over travel when raising the door. Installed through guide after curtain is lowered, they provide definite contact with the bottom bar angle and stop clics.

The **RATCHED SPRING TENSIONER ASSEMBLY** is factory installed on the tension end of door assembly for easy tension / spring adjustment. Tensioner adjusts both springs equally at the same time from only one end of the door.

Roll formed clear acrylic coated galvanized steel **BOTTOM BAR** reinforced with a 1-1/2" x 1-1/2" x 14 gauge full width galvanized angle that extends fully into the guides. The PVC bulb astragal provides positive contact with floor. Lift handles installed on exterior side of bottom bar with interior stop clips and a non - rotting pull rope is attached to the inside angle.

Oil - tempered helical torsion **SPRINGS** are factory lubricated to minimize friction and corrosion while increasing the spring cycle life. Spring wire conforms to ASMA A 229.

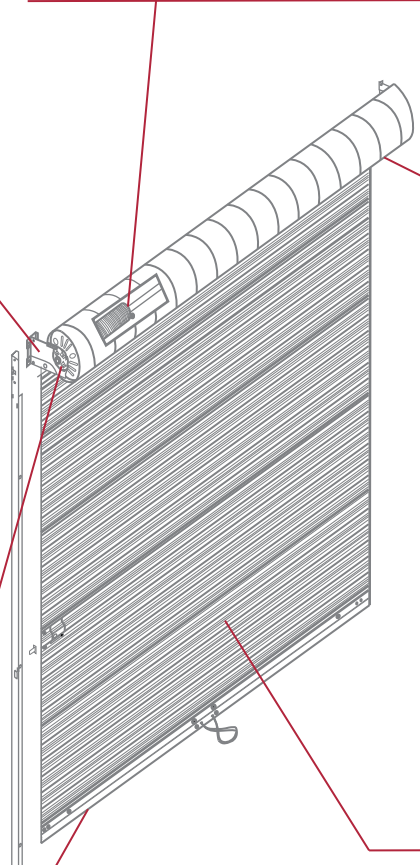

Full width galvanized steel **BARREL** totally encloses the drums, springs and axle. Barrel type construction reduces door sag, eliminates drum dents and improves operation due to an even support of the curtain for the entire width.

Roll formed, 18 gauge galvanized **GUIDES** are fitted with dual polyethylene wear strips to reduce friction and muffle door noises. All guide attachment to jamb is performed through the guides without the addition of clips welded to the back of the guides. This gives a neater appearance, increased strength and aids in tight installations.

Galvanized and pre-painted with long lasting super durable polyester paint, the 26 gauge **CORRUGATED CURTAIN** is roll formed from ASTM A 653 grade 80 steel. This premium steel yields greater door strength and minimized curtain damage. Full height felt tape on inside of curtain prevents nesting and reduces paint rubbing. Available in over 10 different colors.

### Please visit our web site for additional information

- Color chart
- Warranty
- Additional locations
- Other products

 +1 (470) 590 2626

 +1 (770) 543 8034



www.sscornerstoneintl.com  
 jorvis@sscornerstoneintl.com  
 rorvis@sscornerstoneintl.com  
 Office location: 155 Reynolds Road  
 Hiram, GA 30141  
 Fb: SSCornerstone International  
 IG: sscornerstone.usa  
 LinkedIn: SSCORNERSTONE  
 INTERNATIONAL

